

BDTSecureNVR301-S2 Series



Key Features

- Support Ultra 265/H.265/H.264 video formats
- 4/8-channel input
- Third-party IP cameras supported with ONVIF conformance: Profile S, Profile G, Profile T
- Support 1-ch HDMI, 1-ch VGA
- HDMI and VGA simultaneous output
- Up to 6MP resolution recording
- 1 SATA HDD up to 10 TB
- Support cloud upgrade

Specifications

Model	BDTSecureNVR3014S2	BDTSecureNVR3018S2
Video/Audio Input		
IP Video Input	4-ch	8-ch
Network		
Incoming Bandwidth	40Mbps	50Mbps
Outgoing Bandwidth	40Mbps	40Mbps
Remote Users	128	
Protocols	P2P, UPnP, NTP, DHCP, PPPoE	
Video/Audio Output		
HDMI/VGA Output	HDMI: 1920x1080p/60Hz, 1920x1080p/50Hz, 1600x1200/60Hz, 1280x1024/60Hz, 1280x720/60Hz, 1024x768/60Hz VGA: 1920x1080p/60Hz, 1920x1080p/50Hz, 1600x1200/60Hz, 1280x1024/60Hz, 1280x720/60Hz, 1024x768/60Hz	
Audio Output	1-ch, RCA	
Recording Resolution	6MP/5MP/4MP/3MP/1080p/960p/720p/D1/2CIF/CIF	
Synchronous Playback	4-ch	8-ch
Corridor Mode Screen	3/4	3/4/5/7/9
Decoding		

Decoding format	Ultra 265/H.265/H.264
Liveview/Playback	6MP/5MP/4MP/3MP/1080p/960p/720p/D1/2CIF/CIF
Capability	1 x 6MP@20, 1 x 5MP@30, 2 x 4MP@25, 2 x 3MP@30, 4 x 1080p@25, 8 x 960p@25, 8 x 720p@30
Hard Disk	
SATA	1 SATA interface
Capacity	up to 10TB for each disk
External Interface	
Network Interface	1 RJ45 10M/100M self-adaptive Ethernet Interface
USB Interface	Rear panel: 2 x USB2.0
Supported Standard	IEEE 802.3at, IEEE 802.3af
General	
Power Supply	12V DC Power Consumption: ≤ 9 W (without HDD)
Working Environment	-10°C ~ + 55°C (+14°F ~ +131°F), Humidity $\leq 90\%$ RH (non-condensing)
Dimensions (W×D×H)	260mm × 240mm × 46mm (10.2"×9.4"×1.8")
Weight (without HDD)	1kg (2.20 lb)

Dimensions

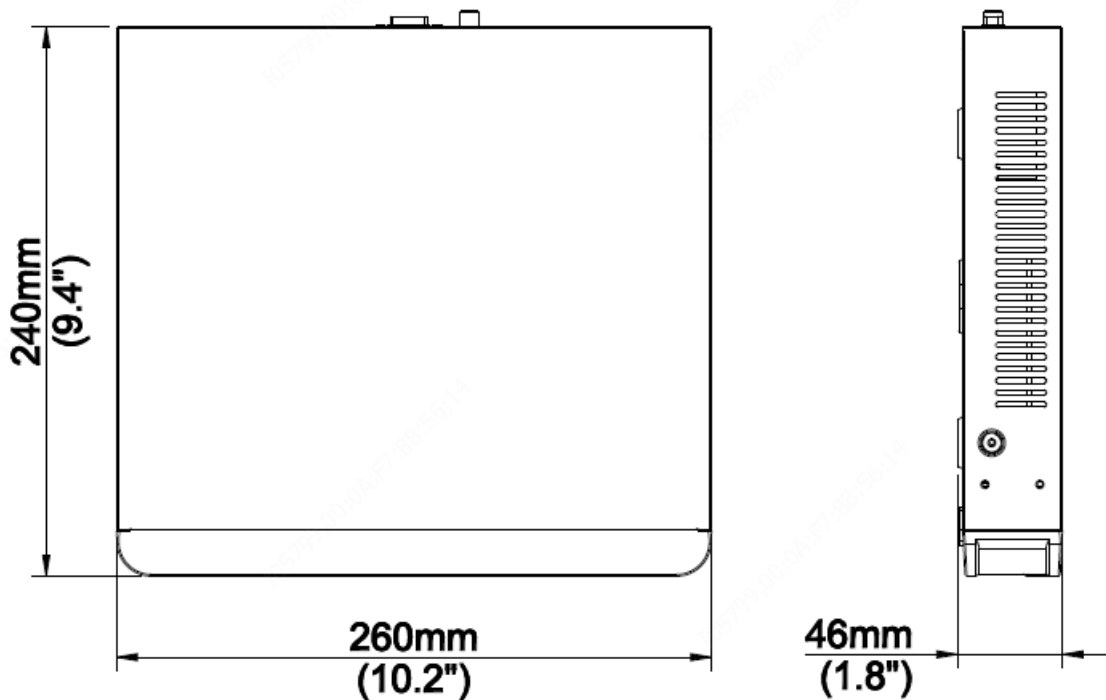

Rear Panel

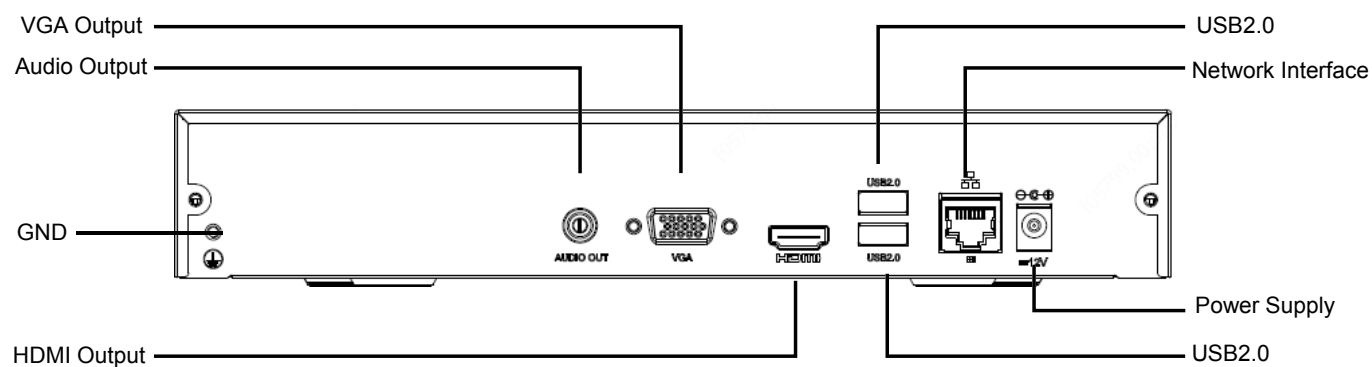

“Your Reliable Integrated Video Surveillance Solutions Provider”

Shenzhen Starlink Technology Co.,Ltd

1811, Block A, Zhantao Technology Building, Longhua District, Shenzhen, P.R.China
518131

Email: info@qixingtechnology.com; qixing@qixingtechnology.com

<https://www.qixingtechnology.com>

©2009-2018 Shenzhen Starlink Technology Co.,Ltd. All rights reserved.

*Product specifications and availability are subject to change without notice.