

## TR-WE45-D-IN Multi-sensor Panoramic Camera Wall Mount



### Specifications

Bracket	TR-WE45-D-IN
Application	Indoor or outdoor, Multi-sensor Panoramic Network Camera Wall installation
Dimensions	225.0mmx111.3mmx150.6mm(8.9" x 4.4"x 5.9")
Weight	0.58kg (1.28lb)
Material	Aluminum alloy

## Dimensions

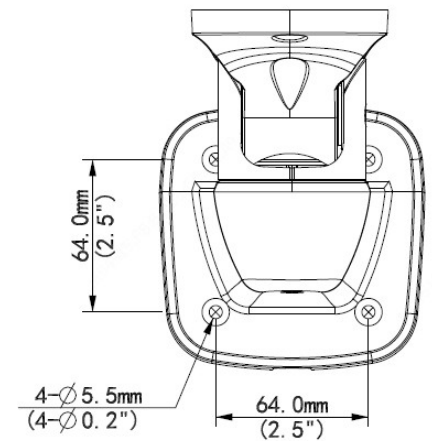
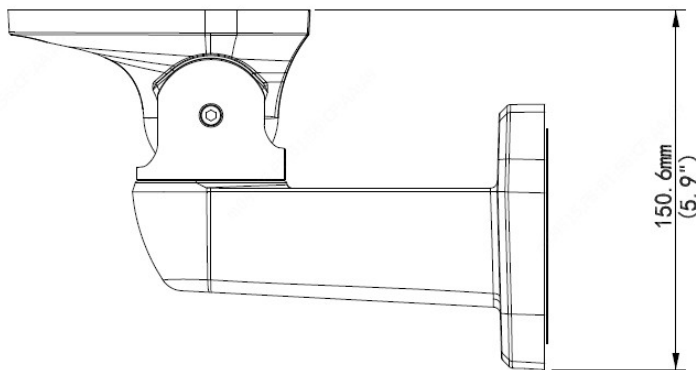
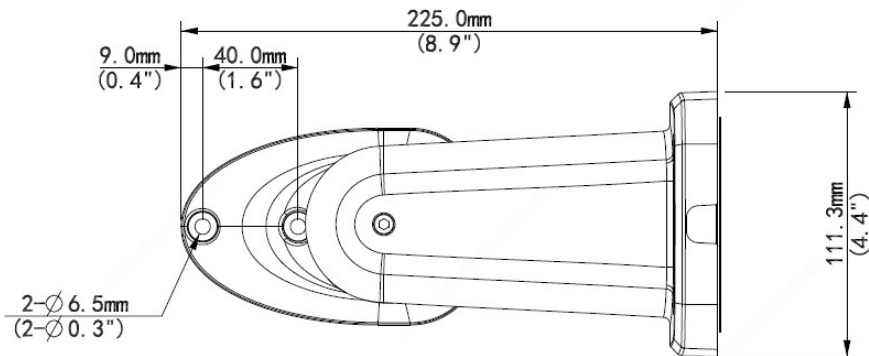

**“Your Reliable Integrated Video Surveillance Solutions Provider”**

**Shenzhen Starlink Technology Co.,Ltd**

1811, Block A, Zhantao Technology Building, Longhua District, Shenzhen, P.R.China 518131

Email: info@qixingtechnology.com; qixing@qixingtechnology.com

<https://www.qixingtechnology.com>

©2009-2018 Shenzhen Starlink Technology Co.,Ltd. All rights reserved.

\*Product specifications and availability are subject to change without notice.