

TR-UP08-A-IN Pole Mount Adapter

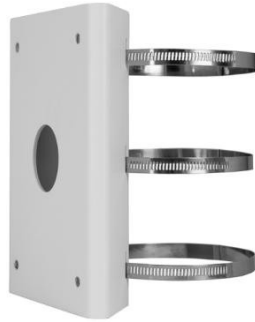

Specifications

Bracket	TR-UP08-A-IN
Application	Indoor or outdoor, pole installation for PTZ dome camera
Dimensions(L x W x H)	215mmx170mmx52mm (4.7"x4.7"x2.1")
Weight	1.47kg(3.2lb)
Material	Steel

Dimensions

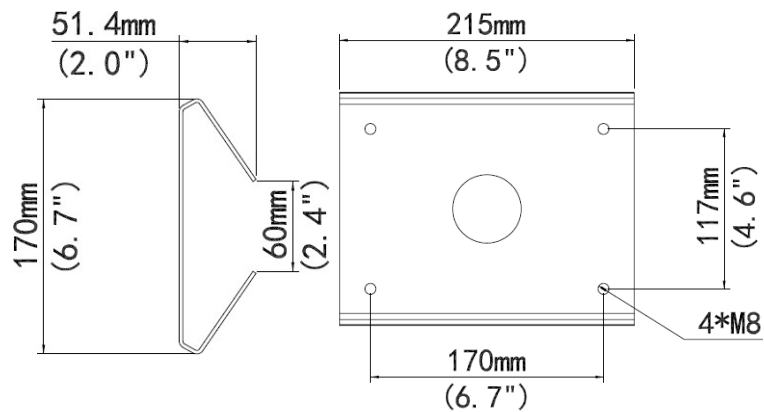

“Your Reliable Integrated Video Surveillance Solutions Provider”

Shenzhen Starlink Technology Co.,Ltd

1811, Block A, Zhantao Technology Building, Longhua District, Shenzhen, P.R.China 518131

Email: info@qixingtechnology.com; qixing@qixingtechnology.com

<https://www.qixingtechnology.com>

©2009-2018 Shenzhen Starlink Technology Co.,Ltd. All rights reserved.

*Product specifications and availability are subject to change without notice.