

TR-WE45-A-IN PTZ Dome Wall Mount



Specifications

Bracket	TR-WE45-A-IN
Application	Indoor or outdoor, wall installation for PTZ dome camera
Dimensions(L x W x H)	216mmx141mmx314mm(8.5" x 5.6"x 12.4")
Weight	1.0kg(2.2lb)
Material	Aluminum alloy

Dimensions

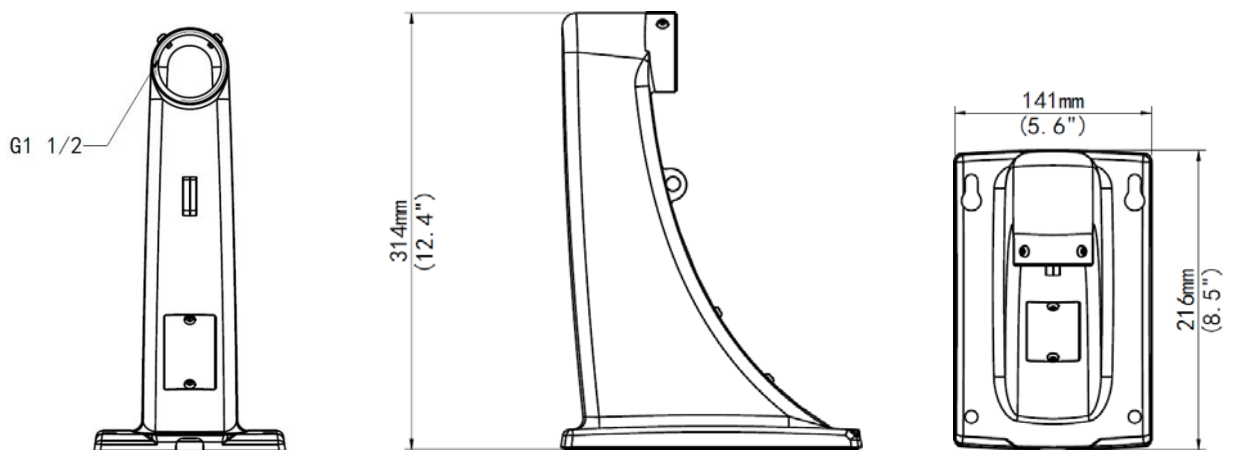

“Your Reliable Integrated Video Surveillance Solutions Provider”

Shenzhen Starlink Technology Co.,Ltd

1811, Block A, Zhantao Technology Building, Longhua District, Shenzhen, P.R.China 518131

Email: info@qixingtechnology.com; qixing@qixingtechnology.com

<https://www.qixingtechnology.com>

©2009-2018 Shenzhen Starlink Technology Co.,Ltd. All rights reserved.

*Product specifications and availability are subject to change without notice.